

**HUNGERFORD & TERRY, INC.**

**SYSTEM PERFORMANCE EVALUATION**



***STAY CONNECTED!***



# PRESERVE THE INTEGRITY OF THE ORIGINAL DESIGN WITH GENUINE H&T PARTS

Your water treatment system was engineered and manufactured with pride by the employee owners of Hungerford & Terry, Inc. You can preserve the integrity of the original design by insisting on replacement components and subassemblies from Hungerford & Terry, Inc. Always contact Hungerford & Terry, Inc. for high quality replacement parts.

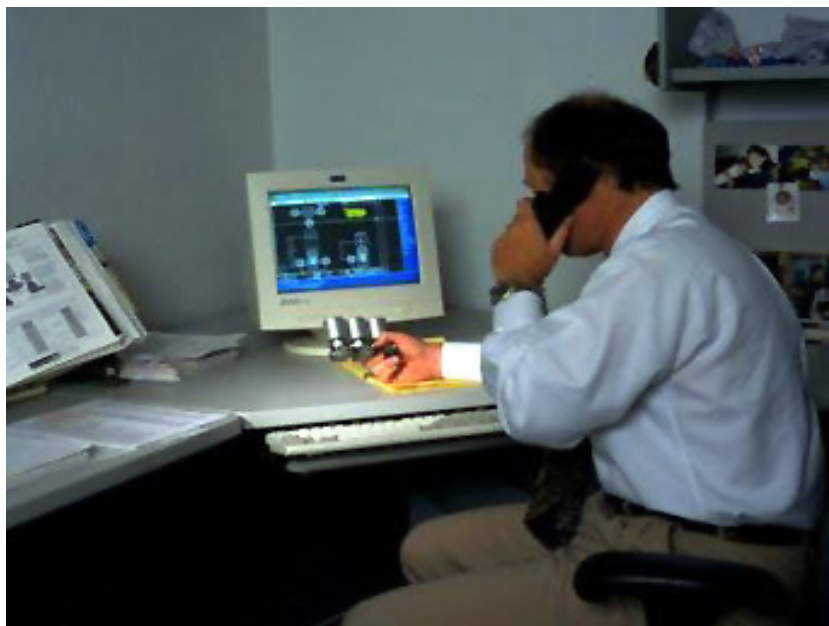

---

## OPTIMIZE EQUIPMENT PERFORMANCE



Change is inevitable. Raw water contaminant concentrations may vary, leading to inefficiencies in regenerant consumption and backwash waste generation.

In addition, water treatment processes are constantly refined, leading to more efficient use of regenerants, and new methods of minimizing waste.

An annual equipment survey, and core specimen extraction can help to identify problems early, refresh operator knowledge, and insure optimal equipment performance

# HUNGERFORD & TERRY, INC.

## PREPAID SYSTEM PERFORMANCE EVALUATION

*Keeps it like new*

Hungerford & Terry's System Performance Evaluation Program Includes:

- On-site surveys conducted by a factory trained service technician
- Equipment adjustments as required
- Core media extraction and analysis
- Raw water and treated water analysis
- Review of system operation and periodic maintenance schedule
- Refresher training in operation and maintenance
- A comprehensive written report outlining key findings and recommendations from the site survey

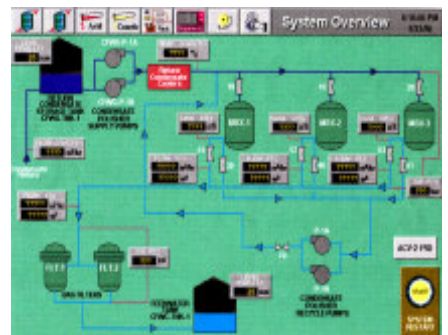

# *A COMMITMENT TO QUALITY*



The employee / owners of Hungerford & Terry, Inc. are committed to providing the finest quality products and services to its customers.

## **HUNGERFORD & TERRY, INC.**

P.O. Box 650

226 Atlantic Avenue

Clayton, NJ 08312

Telephone: (856) 881-3200

Fax: (856) 881-6859

E-mail: [mail@hungerfordterry.com](mailto:mail@hungerfordterry.com)